



台 宙 晶 體 科 技 股 份 有 限 公 司

Top Crystal Technology Inc.,

Power Light Source

Introduction :

THEM-CLX is one the highest flux LEDs in the world. Due to the special design of chip and package, the THEM-CLX is designed by particular package for high power LED.

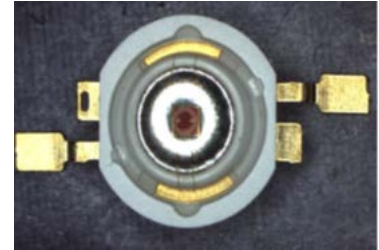

Feature :

- Long operating life
- Energy efficiency
- Low thermal resistance
- Compact design
- Instant light
- Fully dimmable
- No UV
- Superior ESD protection
- ROHS compatibility

Typical Applications:

- Reading lights
- Portable light
- Orientation
- Entertainment
- Garden
- Security light
- Ceiling light
- Architectural lighting
- General lighting
- Jewel display illumination



台 宙 晶 體 科 技 股 份 有 限 公 司
Top Crystal Technology Inc.,

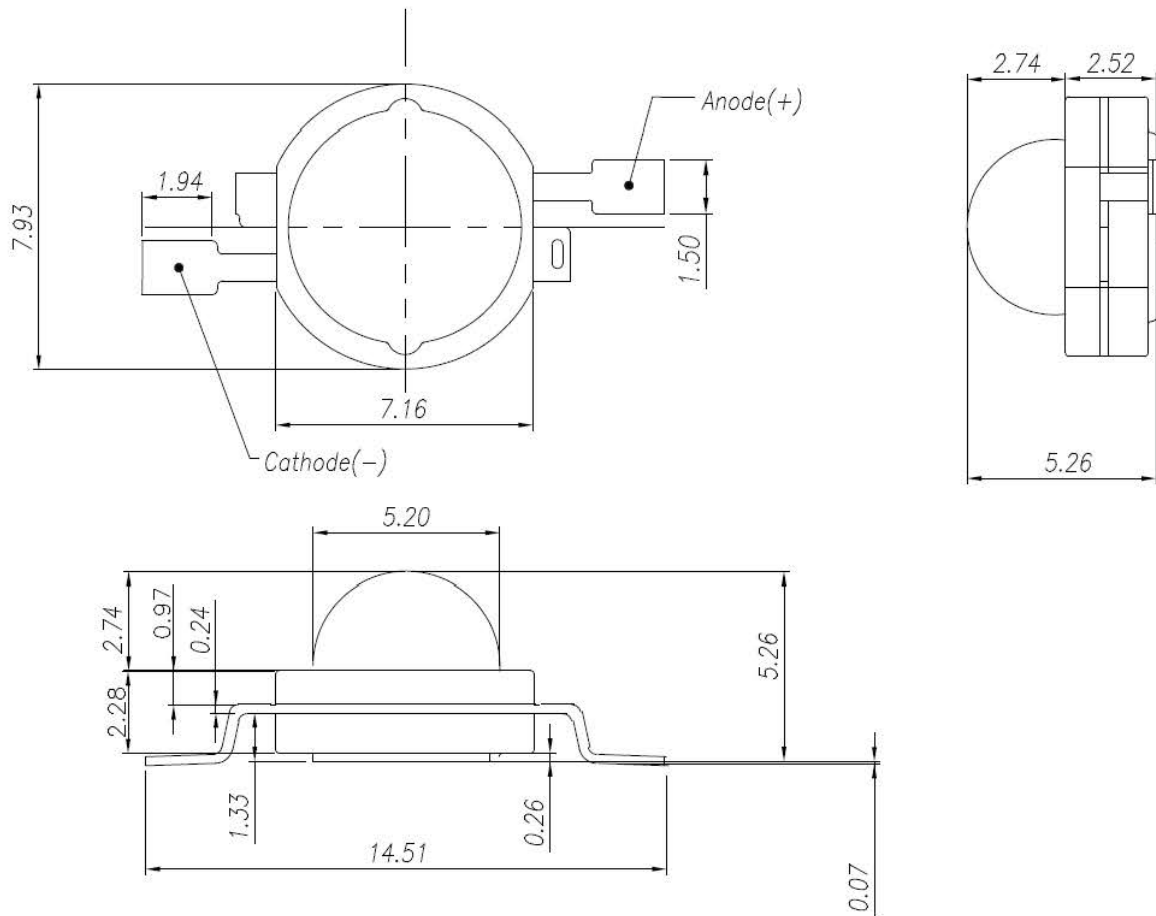

Notes :

1. Drawings are not to scale.
2. All dimensions are in millimeter.
3. General tolerance is $\pm 0.2\text{mm}$.
4. The polarity of slug at bottom is anode.
5. It is important that the slug can't contact aluminum surface, it is strongly recommended that there should coat a uniform electrically isolated heat dissipation film on the surface.
6. It is strongly recommended that the temperature of lead be not higher than 70°C .



台 宙 晶 體 科 技 股 份 有 限 公 司

Top Crystal Technology Inc.,

Absolute Maximum Ratings

Parameter	Conditions	
DC Forward Current	1W	350mA
	3W	700 mA
Peak Pulse Current (mA)	1W	500 mA
	3W	900 mA
LED Junction Temperature (°C)	120°C	
Operating Temperature (°C)	-30~100	
Storage Temperature (°C)	-40~120	
Soldering Temperature	Manual 250°C(max) 5 seconds	
Reverse Voltage	Not design to be driven in reverse bias	

Notes :

1. Proper current derating must be observed to maintain junction temperature below the maximum at all time.
2. Allowable reflow cycles are 3 times for each LED

Optical Characteristics (T_j=25°C)

Color	Dominant Wavelength λ _d		Viewing Angle Degree 2θ _{1/2}
	Min.	Max.	
Royal Blue	450nm	460nm	150
Blue	455nm	475nm	150
Cyan	495nm	515nm	150
Green	515nm	535nm	150
Amber	585nm	597.5nm	130
Red	615nm	630nm	130
Crimson[1]	650nm	670nm	130

Notes :

1. [1] : Peak Wavelength (λ_p)
2. CCT (Wavelength) ±5% tester tolerance.
3. Wavelength is measured with an accuracy of ±0.5nm.



台 宙 晶 體 科 技 股 份 有 限 公 司

Top Crystal Technology Inc.,

Flux Characteristics (T_j=25°C)

Color	Forward current	Part Number	Minimum Luminous Flux(lm)	Typical Luminous Flux(lm)	Maximum Luminous Flux(lm)	Beam Pattern
Royal Blue	350mA	THEM-CLY	450mW	650mW	--	Lambertian
	700mA	THEM-DLY	850 mW	1100mW		
Blue	350mA	THEM-CLB	24Lm	30Lm	--	
	700mA	THEM-DLB	40Lm	50 Lm		
Cyan	350mA	THEM-CLC	65Lm	80Lm	--	
	700mA	THEM-DLC	110Lm	135 Lm		
Green	350mA	THEM-CLG	100Lm	120Lm	--	
	700mA	THEM-DLG	170Lm	195 Lm		
Amber	350mA	THEM-CLA	55Lm	75Lm	--	
	700mA	THEM-DLA	95Lm	120 Lm		
Red	350mA	THEM-CLR	45Lm	65Lm	--	
	700mA	THEM-DLR	95Lm	125 Lm		
Crimson	350mA	THEM-CLP	320mW	450mW	--	
	700mA	THEM-DLP	550mW	700mW		

- TCI maintains a tolerance of $\pm 7\%$ on flux and power measurements.
- Please do not drive at rated current more than 1 second without proper heat sink.

Electrical Characteristics (T_j=25°C)

Color	Forward current	Part Number	Forward Voltage V _F (V)			Temperature Coefficient of V _F (mV/°C) $\Delta V_F/\Delta T_j$	Thermal Resistance Junction to lead (°C/W)
			Min.	Typ.	Max.		
Royal Blue	350mA	THEM-CLY	2.9	3.3	3.6	-2	10
	700mA	THEM-DLY	3.1	3.6	4.0		
Blue	350mA	THEM-CLB	2.9	3.3	3.6	-2	10
	700mA	THEM-DLB	3.1	3.6	4.0		
Cyan	350mA	THEM-CLC	2.9	3.4	3.7	-2	10
	700mA	THEM-DLC	3.1	3.6	4.0		
Green	350mA	THEM-CLG	2.9	3.4	3.7	-2	10
	700mA	THEM-DLG	3.1	3.6	4.0		
Amber	350mA	THEM-CLA	1.8	2.2	2.8	-2	10
	700mA	THEM-DLA	2.0	2.4	3.0		
Red	350mA	THEM-CLR	1.8	2.2	2.8	-2	10
	700mA	THEM-DLR	2.0	2.4	3.0		
Crimson	350mA	THEM-CLP	1.8	2.2	2.8	-2	10
	700mA	THEM-DLP	2.0	2.5	3.0		

Notes:

1. V_F $\pm 0.1V$ tester tolerance.



台 宙 晶 體 科 技 股 份 有 限 公 司

Top Crystal Technology Inc.,

RELIABILITY ITEMS and SPECTIONS

No	Test Item	Test Conditions	Remark
1	Room Temperature Operating Life	25°C	1000 hrs
2	High Temperature Storage	Temperature : 110°C	1000 hrs
3	Thermal shock	-40°C to 120°C, 20 min. dwell, <20 sec. transfer	200 cycles
4	High Temperature , High Humidity Storage	85°C/85%RH	1000 hrs
5	Low Temperature Storage	- 40°C	1000 hrs
6	Solderability	Tp = 260°C for 5 sec	3 times
7	Drop test	120 cm height , fall freely onto stainless board	3 times
8	Temperature Cycle (TMCL)	-40°C to 120°C, 30 min. dwell, <5 min. transfer	200 cycles

Failure Criteria :

1. Forward Voltage (VF) \geq Initial Level x 1.1
2. Luminous Flux or Radiometric Power (ΦV) \leq Initial Level x 0.7
3. Reverse Current (IR) \geq 10 μ A
4. Resistance to Soldering Heat : No deaqd lamps or visual damage.



台 宙 晶 體 科 技 股 份 有 限 公 司 Top Crystal Technology Inc.,

Wavelength Spectrum, Ta=25 °C

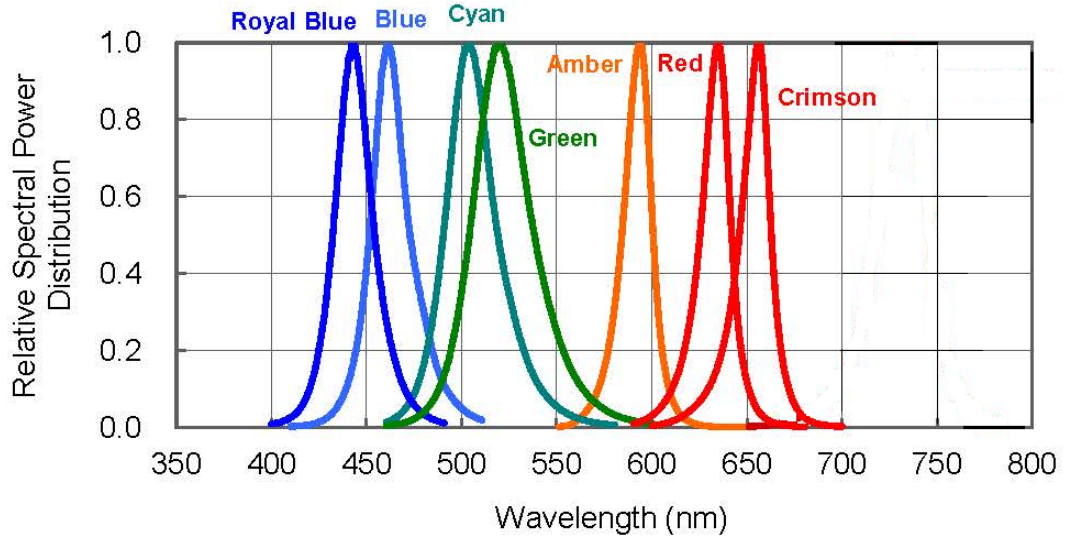



Typical Spatial Radiation Pattern

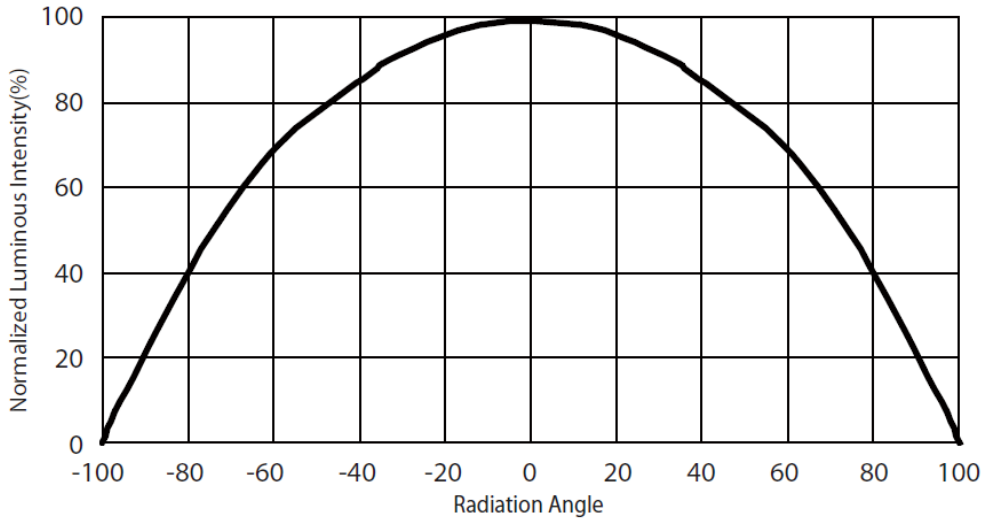

Radiation Pattern for Royal Blue 、 Blue 、 Cyan 、 Green

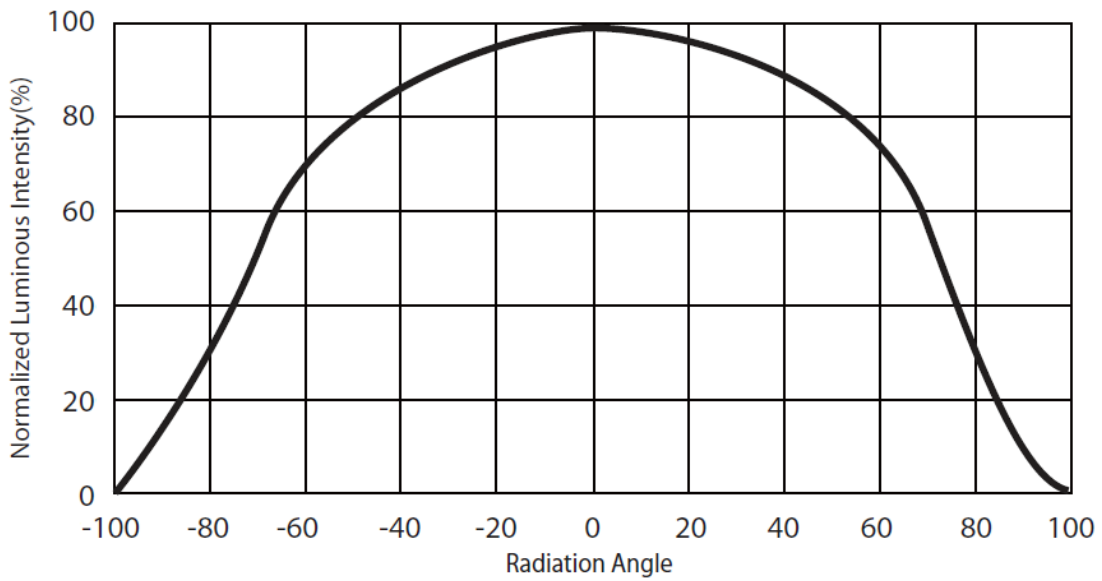

Radiation Pattern for Amber 、 Red 、 Crimson



台 宙 晶 體 科 技 股 份 有 限 公 司 Top Crystal Technology Inc.,

Forward current vs. Forward Voltage Characteristics

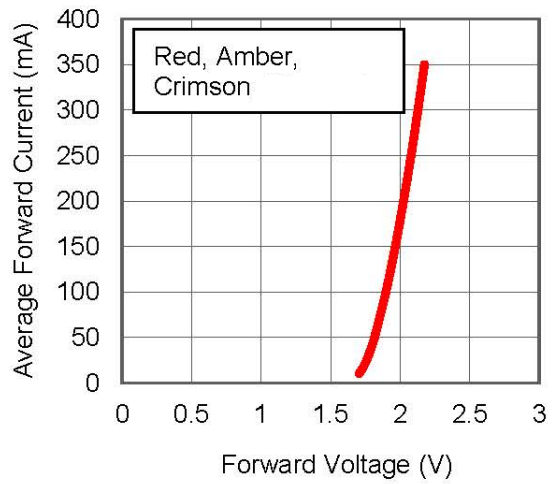
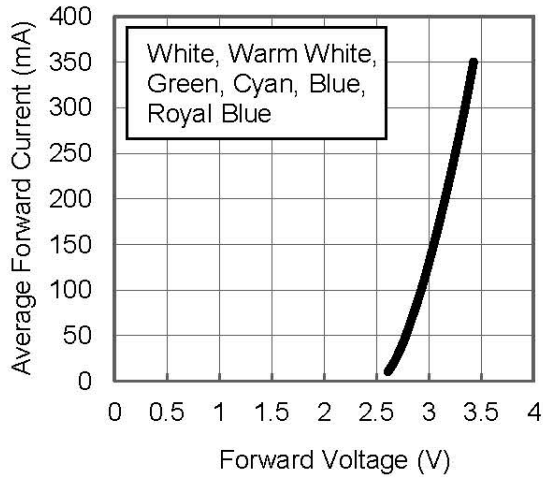

Relative intensity vs. Forward Current

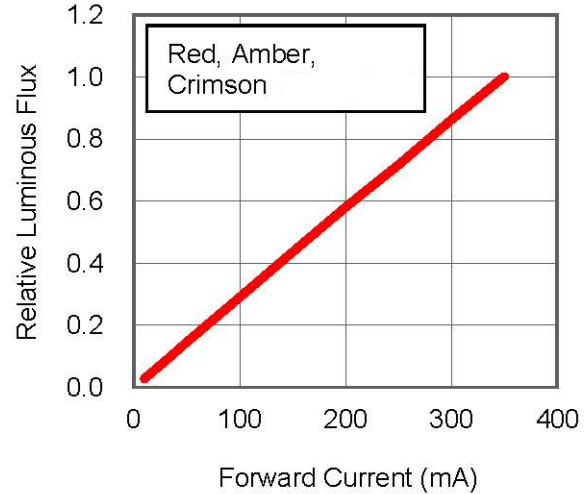
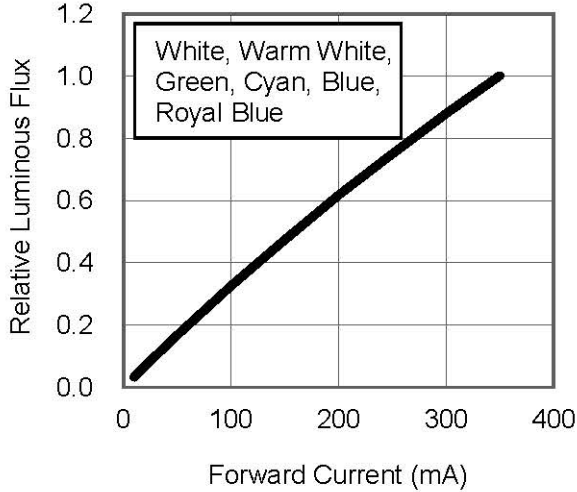



台 宙 晶 體 科 技 股 份 有 限 公 司 Top Crystal Technology Inc.,

Ambient Temperature vs. Maximum Forward Current

Green, Cyan, Blue, Royal Blue ($T_{JMAX} = 120^{\circ}C$)

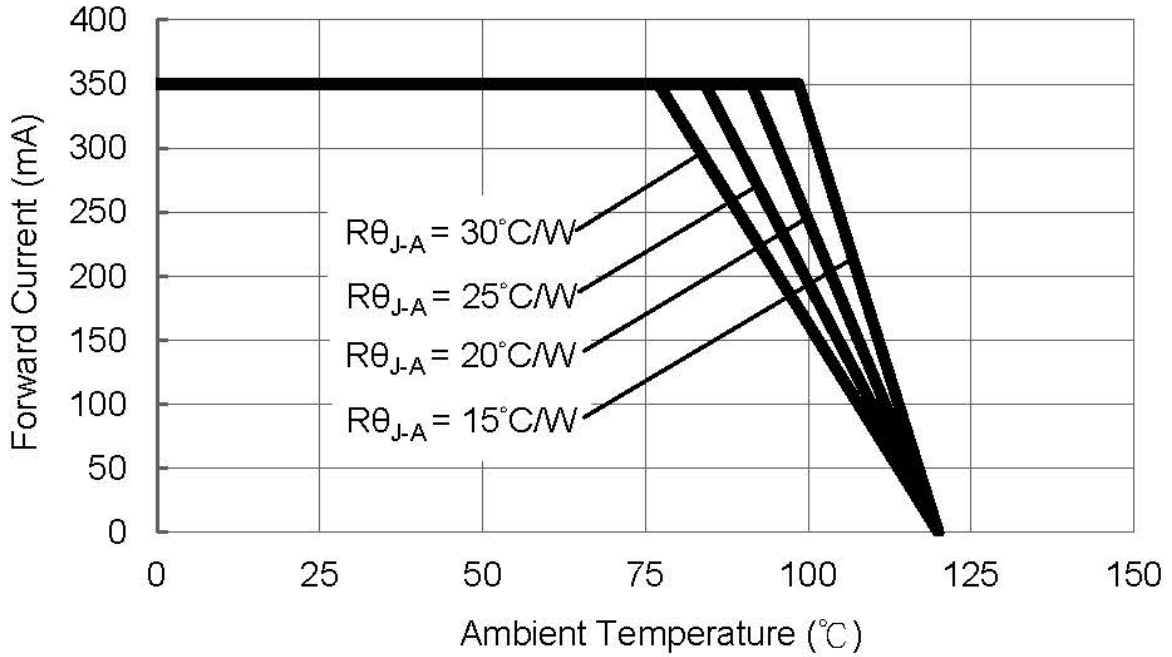

Red, Amber, Crimson ($T_{JMAX} = 120^{\circ}C$)

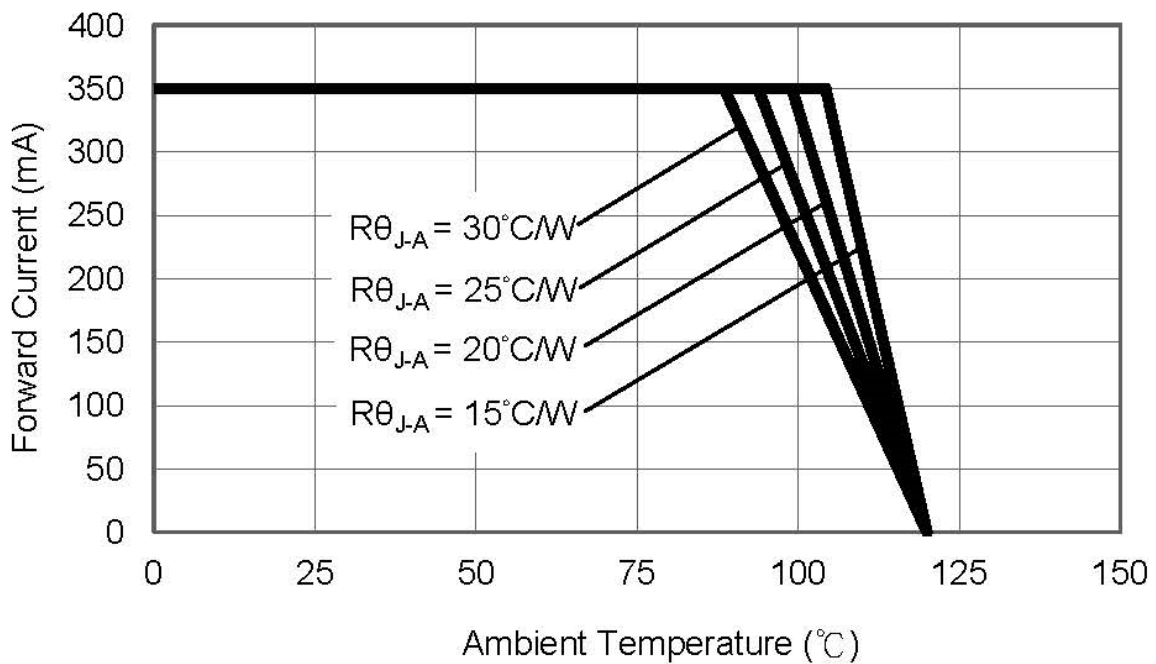



Light Output Characteristics

Relative Light Output vs. Junction Temperature at 350mA

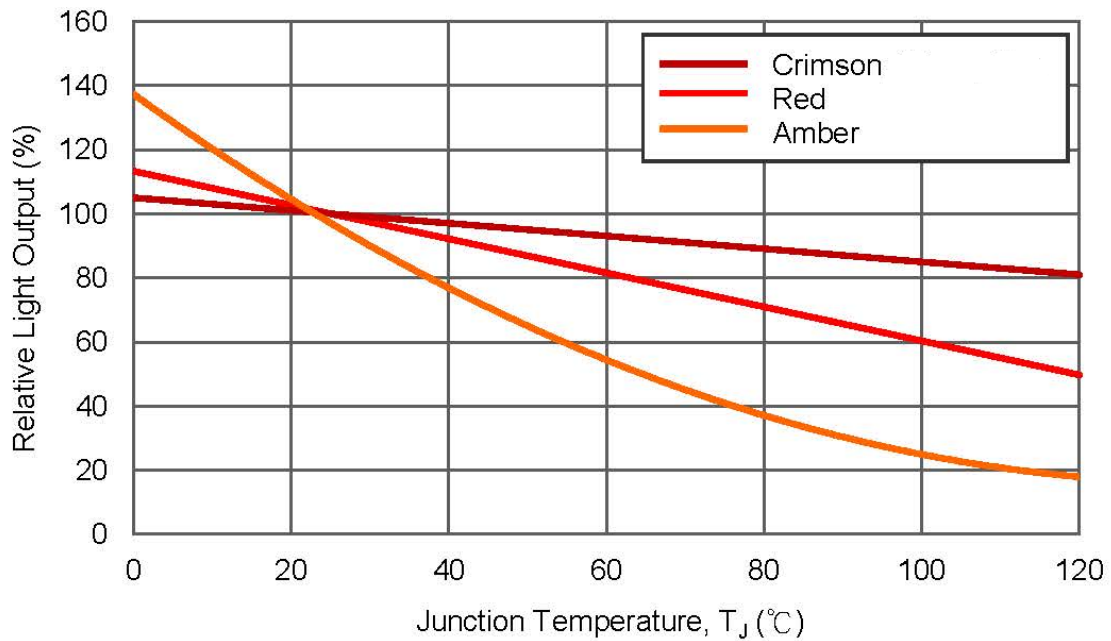
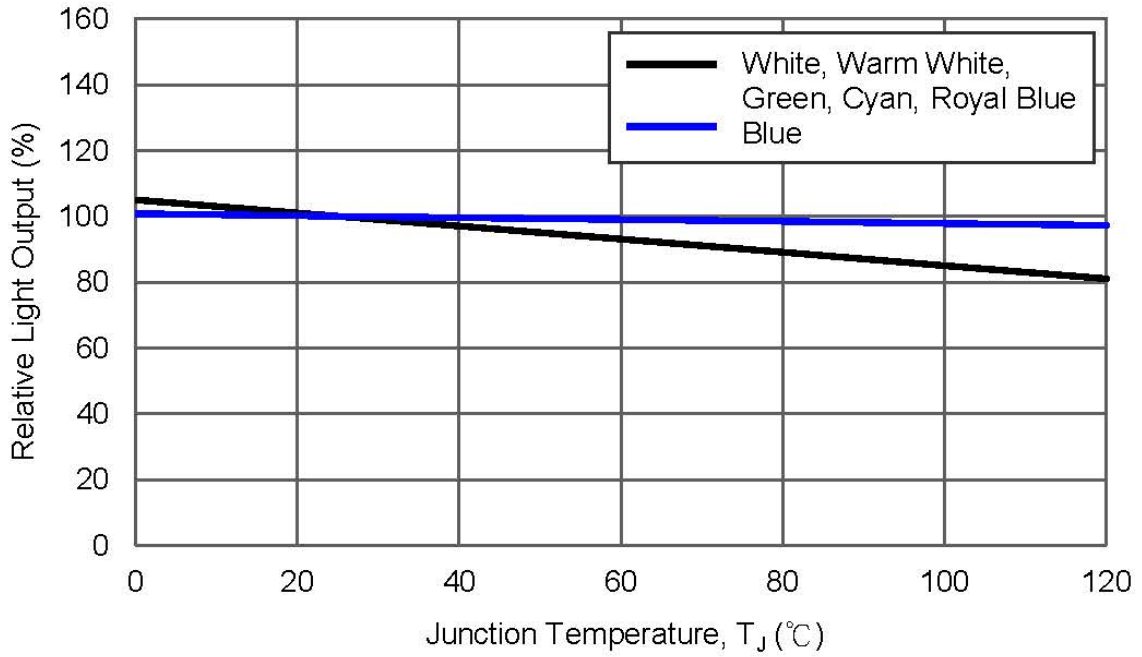



Recommended Solder Pad Design

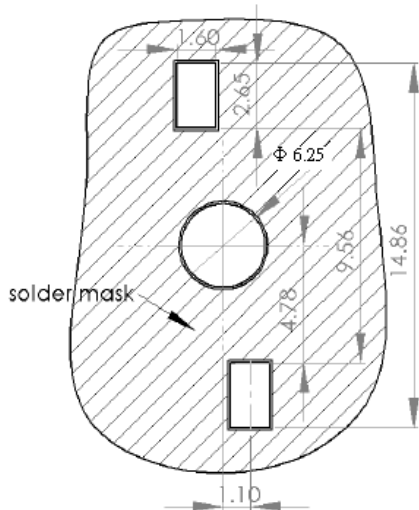

Notes :

1. Drawing is not to scale
2. All dimensions are in millimeter
3. Solder pad can't be connected to slug

5. Recommended nozzle style

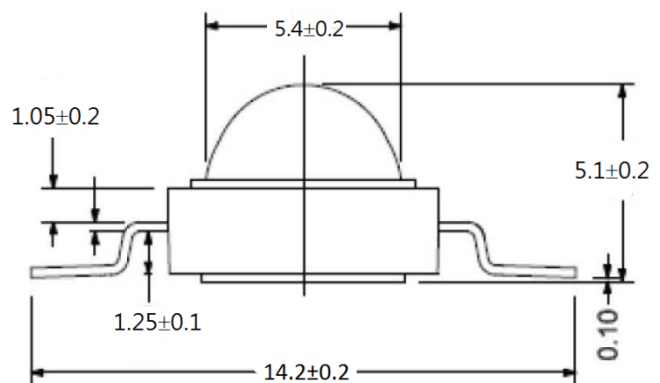
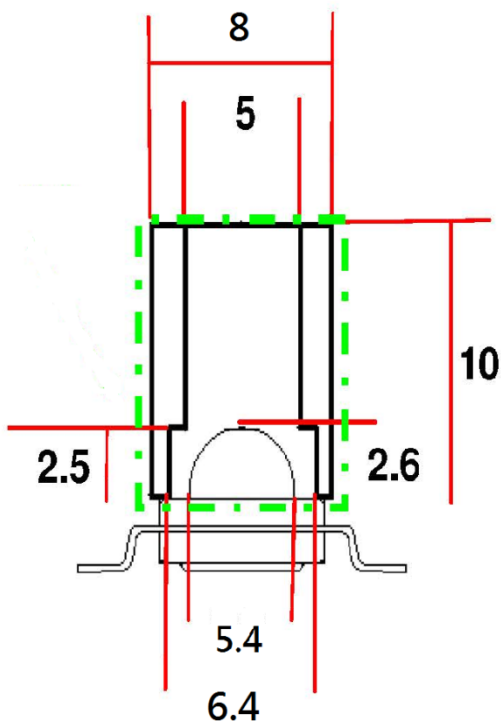



台 宙 晶 體 科 技 股 份 有 限 公 司

Top Crystal Technology Inc.,

Recommended Soldering Profile

The LEDs can be soldered using the parameter listed below. As a general guideline, the users are suggested to follow the recommended soldering profile provided by the manufacturer of the solder paste. Although the recommended soldering conditions are specified in the list, reflow soldering at the lowest possible temperature is preferred for the LEDs.

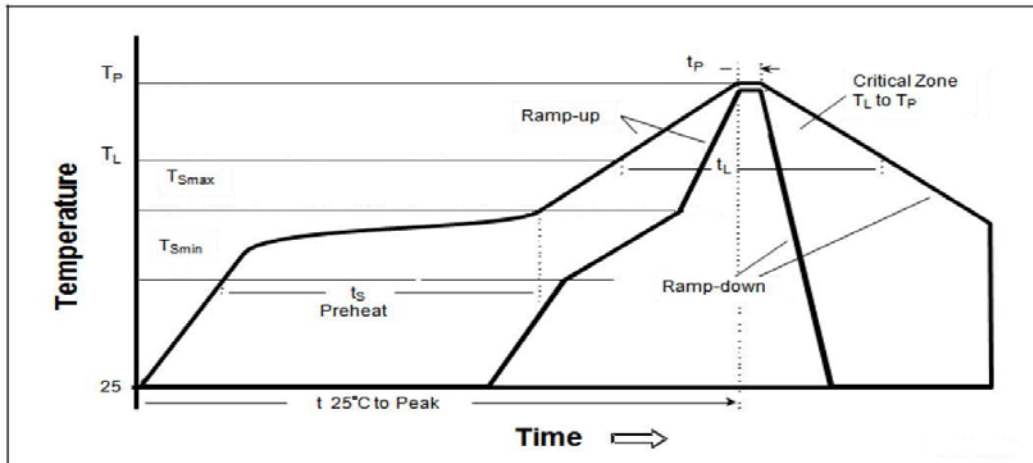

Profile Feature	Sn-Pb Eutectic Assembly	Pb-Free Assembly
Average Ramp-Up Rate (T _{Smax} to T _P)	3°C / second max.	3°C / second max.
Preheat – Temperature Min (T _{Smin}) – Temperature Max (T _{Smax}) – Time (t _{Smin} to t _{Smax})	100°C 150°C 60-120 seconds	150°C 200°C 60-180 seconds
Time maintained above: – Temperature (T _L) – Time (t _L)	183°C 60-150 seconds	190°C 60-150 seconds
Peak/Classification Temperature (T _P)	230°C	250°C
Time Within 5°C of Actual Peak Temperature (t _p)	5 seconds	5 seconds
Ramp-Down Rate	6°C/second max.	6°C/second max.
Time 25°C to Peak Temperature	6 minutes max.	8 minutes max.

- All temperatures refer to topside of the package, measured on the package body surface.
- Repairing should not be done after the LEDs have been soldered. When repairing is unavoidable, a double-head soldering iron should be used. It should be confirmed beforehand whether the characteristics of the LEDs will or will not be damaged by repairing.
- Reflow soldering should not be done more than three times.
- When soldering, do not put stress on the LEDs during heating.
- After soldering, do not warp the circuit board.



台 宙 晶 體 科 技 股 份 有 限 公 司
Top Crystal Technology Inc.,



Tube Package Specifications

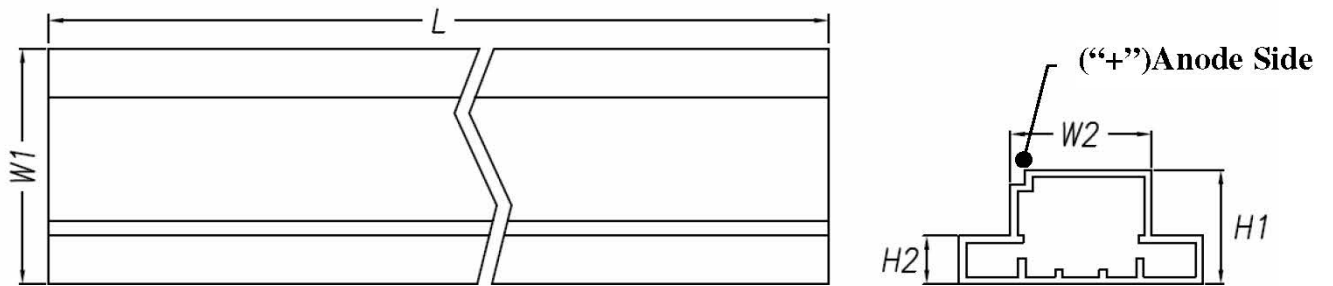
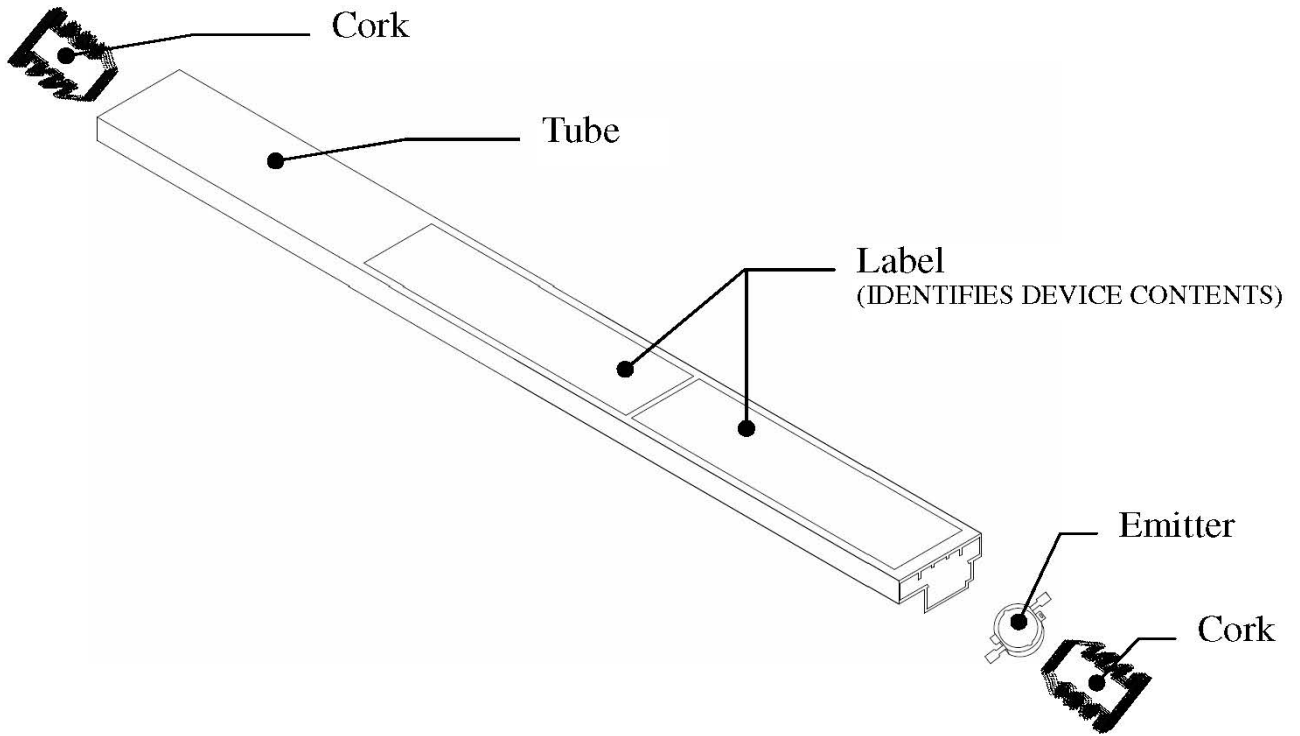

Unit : mm

W1	W2	H1	H2	L
16.5	9.6	8	3.4	424

Notes

1. There are 50pcs emitters in a tube.



台 宙 晶 體 科 技 股 份 有 限 公 司

Top Crystal Technology Inc.,

Tape and Reel Packaging Specifications

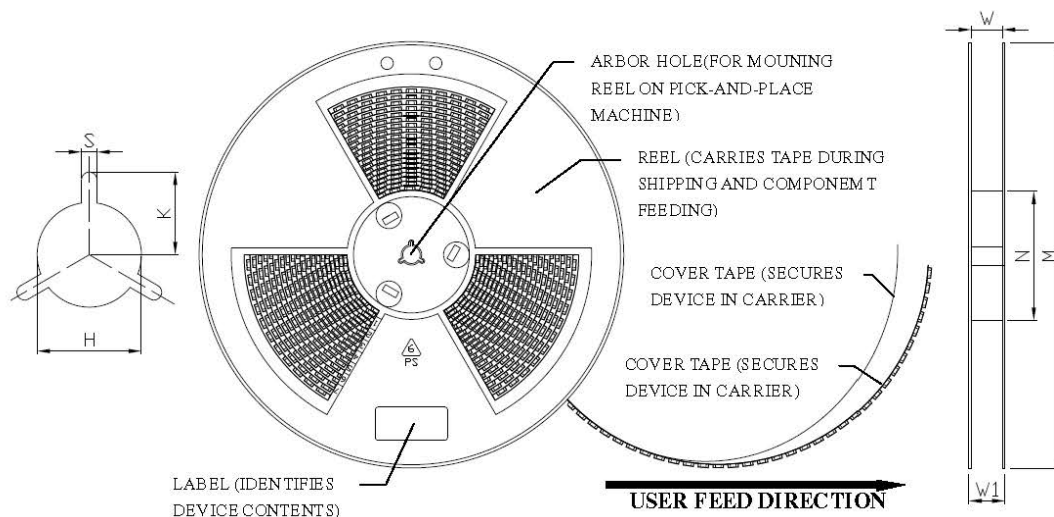

Unit : mm

M	N	W	W1	H	K	S
Φ330.0	Φ99.5	24.4	29	Φ13.5	10.75	2.5
±1.0	±1.0	±1.0	±1.0	±0.5	±0.5	±0.5

Carrier tape dimensions

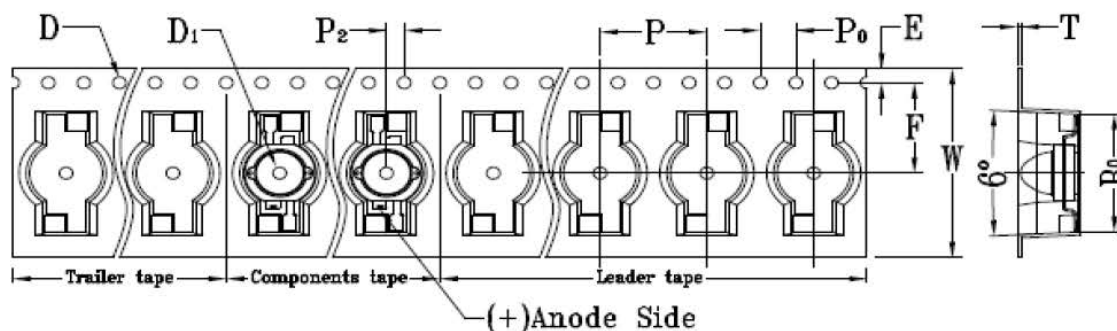

Unit : mm

W	P	E	F	P ₂	D	D ₁	P ₀	A ₀	B ₀	K ₀	T
24.0	12.0	1.75	11.5	2.0	1.5	1.5	4.0	8.2	15.0	6.7	0.4
±0.3	±0.1	±0.1	±0.1	±0.1	±0.1	±0.25	±0.1	±0.1	±0.1	±0.1	±0.05



台 宙 晶 體 科 技 股 份 有 限 公 司

Top Crystal Technology Inc.,

Notice

1. Unavailable directly touch the colloid surface and squeeze
2. Use tweezers to pick up the external sides of the housing part carefully. Do not grab, puncture or push the emitting region. Over stress on the lens may cause the damage of component and raise the risk to break the wire inside the package.
3. In order to avoid absorption of moisture, it is recommended that the products are stored in the dry box (or desiccators) with a desiccants. Alternatively the following environment is recommended: Storage temperature : 5°C~30°C Humidity:60% HR max.
4. If the storage conditions are of high humidity the product should be dried before use. Recommended drying conditions: 12 hours at 60°C±5°C
5. Any mechanical force or any excess vibration should be avoid during the cooling process after soldering.
6. Reflow rapidly cooling should be avoided.
7. Components should not be mounted on distorted Printed Circuit Boards.
8. Devices should not contact with any types of fluid, such as water , oil , organic solvents.... etc.
9. The maximum ambient temperature should be taken into consideration when determining the operating current.

